

LITTERSMART



SMARTER LITTER MANAGEMENT

INTRODUCTION

LITTERSMART is a 100% Australian designed and manufactured product.

Littersmart will not leak, so there is no risk of damaging stains and is extremely durable and will not break, chip or crack under normal working conditions.

An easy to handle, light weight solution to litter management.

For security, Littersmart can be wired to prevent component loss or theft.

Littersmart is safe for both indoor and outdoor use. UV stabilised and will not rust or corrode. Littersmart comes with a 10 year warranty.

Littersmart comes in a range of colours. Refer to our colour selector and colour chips.

Littersmart is recyclable and also available in 100% Recycled Polyethylene.

LitterSmart bins can be found in the following Australian businesses and locations.

- 7-Eleven Fuel and Franchise Outlets
- Freedom Fuel Outlets
- QANTAS Transit Lounge
- Sydney Convention Centre
- Sydney Entertainment Centre
- Brisbane Convention Center
- Gold Coast Convention Center
- Chandler Sports Center
- Westfield Chermiside
- Garden City Shopping Centre
- Castle Hill Shopping Centre
- Tree Tops Shopping Centre
- Morayfield Shopping Centre
- University of Technology Sydney
- RMIT University Campus
- Monash University Campus
- Deakin University Campus
- Swinburne University Campus
- Holmesglen TAFE
- AMF Bowling Centres
- Sky City Darwin Casino
- Jupiters Casino
- Treasury Casino
- Logan Hyperdome Shopping Centre

INDEX

1. **Introduction to Littersmart**
2. **Tot by Alexander Lotersztain**
3. **Coral by Brian Steendyk**
5. **Transit Recycle Station**
7. **Olympian**
9. **Chatswood**
11. **Attache**
13. **Diplomat**
15. **Accessories**
16. **Design Solutions**
17. **Product Matrix**
19. **Contact Details**



TOT

TOT BIN by Alexander Lotersztain

Alexander Lotersztain, is the director of Derlot, a multi-disciplinary studio focusing on award winning projects including product, furniture, hotel design, interior design and art direction with clients both nationally and internationally.



TOT senior + junior

When style is an issue, the TOT is the natural choice with its soft curves and squat stance.

- Sleek open top design
- Bayonet style cap
- Low profile Junior TOT available
- Strong and durable
- 100% Recyclable bin and liner
- Co-polymer liner
- Customisable plate logo
- Water fillable cavity for stability
- Wide range of colours
- Lid colour versatility allows for easy design and colour co-ordination for recycling purposes
- Easy to use, clean and maintain

Product Name: TOT	Dimensions (cm)	Capacity (Litres)
----------------------	--------------------	----------------------

TOT - Senior	60 ^Ø x 90 ^H	86
TOT - Junior	46 ^Ø x 70 ^H	40

SPECIFICATIONS:

1. Open top collection
2. Co-polymer liner included with all bins
3. Ergonomic handles built into liners
4. Wide range of colours available
5. Custom signage available
6. EcoSpecified™ when manufactured from 100% recycled polyethylene



CORAL

CORAL BIN & FURNITURE COLLECTION

by Brian Steendyk

Blurring the line between art and product, Brian Steendyk's bold and energetic work creatively conveys an emotive sculptural allure, exploring line, colour and form.



CORAL BENCH

Coral's flowing curves catch your eye and provoke a smile, while exuding elegance to compliment any fashionable space.

Is available in different seating configurations, which can include a sub-irrigated planter at each end.

Suited to both indoor and outdoor environments, Coral comes in a wide range of colours.

- 100% recycleable polyethylene
- EcoSpecified™ when manufactured from 100% recycled polyethylene
- Sub-Irrigated planter module

Now Available!



CORAL PLANTER

The Coral planter brings with it a unique style and panache. The Coral planter cradles plants, presenting them in an elevated position.

Suited to both indoor and outdoor environments. The Coral planter is available in a wide range of colours.

- 100% recycleable polyethylene
- EcoSpecified™ when manufactured from 100% recycled polyethylene
- Sub-Irrigated

Now Available!





CORAL BIN

Coral bin changes the way we think about vessels for waste management. Designed to compliment the Coral collection, the elegant Coral bin is ready to serve. Cleaning is simple and quick, with its streamlined design, Coral bin provides a 79 litre bin liner.

Suited to both indoor and outdoor environments, Coral comes in a wide range of colours.

- Open top design
- 100% recycleable bin and liner
- Security wire available
- Co-polymer liner
- Lid colour versatility allows for easy design and colour co-ordination for recycling purposes
- EcoSpecified™ when manufactured from 100% recycled polyethylene



Product Name:	Dimensions (cm)	Capacity (Litres)
CORAL		
CORAL - Bin	60 ^Ø x 96 ^H	79

COMING SOON

Brian Steendyk's collection of elegant products successfully combines an underlying logic with the panache fans have come to expect.

The award winning designs possess a free-spirited larrikinism that successfully provides the Australian public with sustainable local product solutions for the design focused purchaser.

TRANSIT

A true workhorse for your recycling and waste management.

The Transit Recycle Station was developed for a specific task. Its features embody the essence of what is expected in a modern workplace.



TRANSIT recycle station

The Transit Recycle Station is a streamline interpretation of a modern recycling bin. It provides 2 x 60 litre capacity bin liners, giving a total capacity of 120 litres with many integrated features, which will suit many applications.

The Transit design was developed specifically for QANTAS and their recycling program. QANTAS required an EcoSpecified™ version manufactured from 100% recycled polyethelene

Use of coloured metal spinnings and signage will ensure your recycling is effective.

Transit Bins are installed at QANTAS Terminals Australia wide.

- Functional open top design
- 100% Recyclable bin and liner
- Co-polymer liners
- Wide range of colours
- Strong and durable
- Hinged Lid
- Lockable Lid
- Risk assessment completed



TRANSIT RECYCLE STATION

customised signage options

Customised signage and mould-in graphics is available as an option. The top spinnings come in a set series of colours and shapes, other coloured powder coated spinnings are available on request.

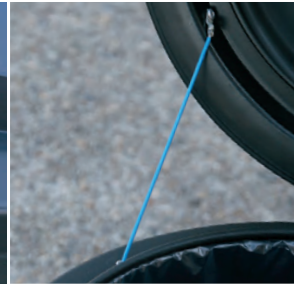

Product Name:
TRANSIT

Dimensions
(cm)

Capacity
(Litres)

TRANSIT Recycle Station

75^L x 50^W x 75^H

2 x 60

INCLUSIONS

1. Key Locking Lid
2. Lid Brace Cable
3. 2 x Bin liners with inbuilt handles

ADDITIONAL OPTIONS

1. Custom Mould-in Graphics
2. Custom Signage
3. Custom Powder Coating
4. Wide Range of Colours



TRANSIT specifications

- Open top collection
- Hinge top design
- Lid brace cable
- Key locking available
- Co-polymer liners included with all bins
- Waste Entry sizes: 19cm & 12.5cm
- Custom powder coating colours available
- Custom mould in graphics available
- Custom signage available
- EcoSpecified™ when manufactured from 100% recycled polyethylene

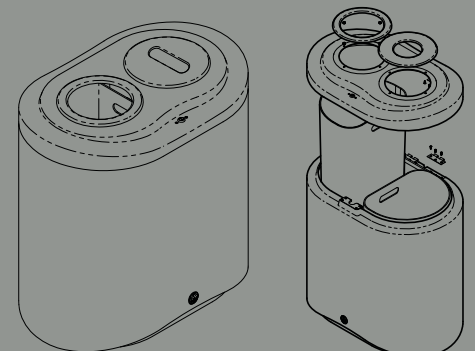

OLYMPIAN

The attractive combination of design, colour and style.

100% Australian Made and designed, featuring open top litter collection and the option of smokers waste collection, makes the Olympian bin the ultimate for large venues. All Olympian Bins are available in 100% recycled polyethylene.



OLYMPIAN shopper

Suited to both indoor and outdoor environments, The Olympian Shopper has been used extensively throughout university campuses, shopping and convention centres.

- Open top design
- Extra wide waste entry
- Strong and durable
- Aluminium top spinning
- Stainless steel band
- 100% Recyclable bin and liner
- Co-polymer liner
- Wide range of colours

OLYMPIAN recycle duo

The attractive combination of function and style. Featuring open top litter collection and recycling utilising multiple bins within the one fixed unit.

- Open top design
- Aluminium top spinnings
- Strong and durable
- Stainless steel bands
- 100% Recycled body and liner
- Co-polymer liner
- Aluminium joiner bar
- Recycling labels
- Waste entry sizes 26.4 cm and 16 cm
- Available as separate units



OLYMPIAN

Container Connection supplies the Olympian series nationally to major public and commercial spaces, shopping centres and sporting venues.

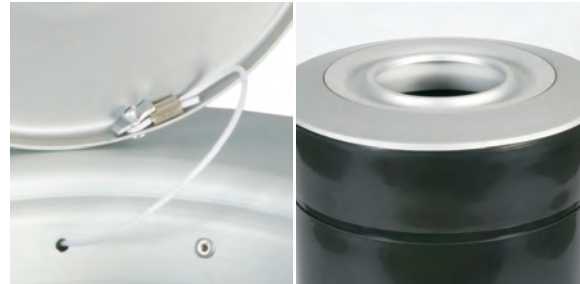

OLYMPIAN specifications

- Open top collection
- High-grade Australian anodised aluminium top spinning
- Co-polymer liners included with all bins
- Ergonomic handles built into liners
- Stainless Steel Band
- Security cable available
- Available in a range of colours including 100% Recycled Black
- Easy to use, clean and maintain
- EcoSpecified™ when manufactured from 100% recycled polyethylene

Product Name:	Dimensions (cm)	Capacity (Litres)
OLYMPIAN		
Shopper Recycle	54 ^Ø x 80 ^H	79
Shopper	54 ^Ø x 80 ^H	79
Shopper Deluxe	54 ^Ø x 80 ^H	79
Shopper Deluxe Recycle	54 ^Ø x 80 ^H	79
Recycle Shopper Duo	115 ^L x 54 ^W x 80 ^H	2 x 79
ADDITIONAL OPTIONS		1. Stainless Steel Band 2. Custom Signage Decals 3. Security Wire 4. Smokers Ash Ring 5. Wide Range of Colours
All models shown include the Deluxe Stainless Base Band		

CHATSWOOD

This range of bins is so versatile for litter and waste management.

The Chatswood is a unique range of litter containers that combine the best in contemporary style with outstanding quality and durability. All Chatswood Bins are available in 100% recycled polyethylene.



CHATSWOOD hooded

The Hooded Range is ideal for shopping centres where recycling and litter management is required. It is also suitable for outdoor environments, to prevent birds from entering the bin. The hooded tops are available in a versatile range of colours for sorting waste from recycled material.

- Side entry design
- Lid colour versatility allows for easy colour co-ordination for recycling purposes
- 100% Recyclable bin and liner
- Co-polymer liner
- Unique easy locking system

CHATSWOOD swing top

Suited to both indoor and courtyard environments, the Chatswood Swing Top Range is ideal for shopping centre foodcourts and cafes.

- Side entry design
- Lid colour versatility allows for easy colour co-ordination for recycling purposes
- 100% Recyclable bin and liner
- Co-polymer liner
- Stainless steel side flaps
- Unique easy locking system

CHATSWOOD tray return top

Suited to both indoor and courtyard environments, the Chatswood Tray Return is ideal for shopping centre foodcourts and cafes.

- Side entry design
- Lid colour versatility allows for easy colour co-ordination for recycling purposes
- stainless steel side flap
- stainless steel top buttons
- 100% Recyclable bin and liner
- Co-polymer liner
- Unique easy locking system



CHATSWOOD

If environmental wellbeing is important to your workplace, the Chatswood bin and liner are available in 100% Recycled Black.

100% recycled black Bin-Liners are included with all bins. The Chatswood series is easy to use, clean and maintain.



CHATSWOOD specifications

- Open side collection
- Easy twist-locking system
- Co-polymer liner included with all bins
- Ergonomic handles built into liners
- High-grade Australian stainless steel fittings on specific bins
- Security cable available
- Lid options available
- Available in a range of colours including 100% Recycled Black
- Custom signage available
- EcoSpecified™ when manufactured from 100% recycled polyethylene



CHATSWOOD open top

Suited to indoor environments, the Chatswood Open Top is ideal for shopping centre foodcourts, restrooms and cafes.

- Open top design
- 100% Recyclable bin and liner
- Co-polymer liner
- Available in a wide range of colours

Product Name: CHATSWOOD	Dimensions (cm)	Capacity (Litres)
Open Top	50 ^L x 50 ^W x 79 ^H	79
Hooded Top 2 Sided Entry	50 ^L x 50 ^W x 96 ^H	79
Hooded Top 4 Sided Entry	50 ^L x 50 ^W x 96 ^H	79
Hooded Top Bottle Opening	50 ^L x 50 ^W x 96 ^H	79
Tray Return Single Entry	50 ^L x 50 ^W x 96 ^H	79
Swing Top 2 Sided Entry	50 ^L x 50 ^W x 96 ^H	79
Swing Top 1 Sided Entry	50 ^L x 50 ^W x 96 ^H	79
ADDITIONAL OPTIONS	<ol style="list-style-type: none"> 1. Security Wire 2. Custom Signage Decals 3. Custom Colour Lids 4. Wide Range of Colours 	

ATTACHE

The attractive combination of design, colour and style.

A slim-line range of bins for a more discreet waste management solution. Made from recyclable polyethylene in a wide range of colours, as well as an EcoSpecified™ recycled version. Personalisation for signage is also available to suit your specifications.



CLASSIC senior and junior

Available in 2 sizes, a larger capacity Classic Senior and a smaller profile Classic Junior. Sleek and durable, the Attache bins are an understated design to suit the modern workplace.

- Open top design
- Stainless steel ring top + base
- Strong and durable
- 100% Recyclable bin and liner
- Co-polymer liner
- Wide range of colours

SLIMLINE senior and junior

The slender profile of the Slimline is ideal for areas short on space. Available in 2 sizes, a larger capacity Senior and a smaller Junior. An understated design to suit the modern workplace.

- Open top design
- Stainless steel ring top + base
- Strong and durable
- 100% Recyclable bin and liner
- Co-polymer liner
- Wide range of colours

ATTACHE recycle duo

Available in 2 sizes, a larger capacity Classic Duo and a smaller Slimline Duo. The Attache Recycle Duos are a great combination to suit the modern workplace.

- Open top design
- Stainless steel ring top + base
- Aluminium joiner bar
- Strong and durable
- 100% Recycled body and liner
- Co-polymer liner
- Wide range of colours
- Available as separate units



ATTACHE

If environmental wellbeing is important to your workplace, the Attache is also available in 100% recycled polyethylene.

The Attache series is easy to use, clean and maintain.





ATTACHE specifications

- Open top collection
- High-grade Australian stainless steel fittings
- 100% Recyclable bin and liner
- Co-polymer liner included with all bins
- Ergonomic handles built into liners
- Security cable available
- Available in multiple configurations
- Litter / Ash side entry available
- Available in a range of colours including 100% Recycled Black
- EcoSpecified™ when manufactured from 100% recycled polyethylene

All models shown include a stainless steel base

Product Name: **ATTACHE**

Product Name:	Dimensions (cm)	Capacity (Litres)
Slimline Open Top Senior	26 ^Ø x 60 ^H	25
Slimline Litter/Ash Senior	26 ^Ø x 60 ^H	18
Slimline Open Top Junior	26 ^Ø x 40 ^H	16.5
Classic Open Top Senior	37 ^Ø x 77 ^H	40
Classic Open Top Junior	37 ^Ø x 62 ^H	20
Slimline Recycle Duo Senior	55 ^L x 26 ^W x 60 ^H	2 x 25
Slimline Recycle Duo Junior	55 ^L x 26 ^W x 40 ^H	2 x 16.5
Classic Recycle Duo Senior	77 ^L x 37 ^W x 77 ^H	2 x 40
Classic Recycle Duo Junior	77 ^L x 37 ^W x 60 ^H	2 x 30

ADDITIONAL OPTIONS

1. Security Wire
2. Custom Signage Decals
3. Wide Range of Colours
4. Aluminium Joiner Bar
5. Stainless Steel Base

DIPLOMAT

Stylish enough to complement the most exclusive environments.

The Diplomat range of litter bins combine classic functionality for commercial spaces and recycling waste management solutions.



DIPLOMAT senior

Combining elegance and function, the Diplomat Senior is both attractive and easy to use. Suitable for restrooms, lobbies and commercial spaces.

- Open top design
- 100% Recyclable bin and liner
- Co-polymer liner
- Anodised aluminium top spinning + base
- Litter / Ash side entry available
- Wide range of colours

DIPLOMAT junior

Where space is an issue, the Diplomat Junior is the perfect choice.

- Open top design
- Low profile design
- Anodised aluminium top spinning + base
- 100% Recyclable bin and liner
- Co-polymer liner
- Litter / Ash side entry available
- Wide range of colours

DIPLOMAT recycle duo

Recycling made easy. Available in 2 sizes, a larger capacity Diplomat Senior Recycle Duo and a lower profile Diplomat Junior Recycle Duo.

- Open top design
- Anodised aluminium top spinning + base
- Aluminium joiner bar
- 100% Recycled body and liner
- 2 x Co-polymer liner
- Litter / Ash side entry available
- Available as separate units



DIPLOMAT

If environmental wellbeing is important to your workplace, the Diplomat is also available in 100% Recycled Black.

The Diplomat series is easy to use, clean and maintain.



DIPLOMAT specifications

- Open top collection
- High-grade Australian anodised aluminium top spinning and plinth
- 100% Recyclable bin and liner
- Co-polymer liner included with all bins
- Ergonomic handles built into liners
- Security cable available
- Available in multiple configurations
- Litter / Ash side entry available
- Available in a range of colours including 100% Recycled Black
- EcoSpecified™ when manufactured from 100% recycled polyethylene

All models shown include the aluminium plinth

Product Name: **DIPLOMAT**

Dimensions (cm)

Capacity (Litres)

Open Top Senior	37 ^ø x 79 ^H	40
Litter/Ash Senior 1 sided Entry	37 ^ø x 79 ^H	30
Litter/Ash Senior 2 sided Entry	37 ^ø x 79 ^H	30
Open Top Junior	37 ^ø x 62 ^H	30
Litter/Ash Junior 1 sided Entry	37 ^ø x 62 ^H	20
Senior Recycle Open Top	37 ^ø x 79 ^H	40
Junior Recycle Open Top	37 ^ø x 62 ^H	30
Recycle Duo Senior	79 ^L x 37 ^W x 79 ^H	2 x 40
Recycle Duo Junior	79 ^L x 37 ^W x 62 ^H	2 x 30

ADDITIONAL OPTIONS

1. Security Wire
2. Custom Signage Decals
3. Wide Range of Colours
4. Aluminium Plinth
5. Aluminium Joiner Bar

ACCESSORIES

Bin Covers + Liner Bags + Cable Security

Dress up that Wheelie Bin with our smart bin covers. Weather proof and easy to install, the covers prevent birds from entering the bin.



BIN COVERS wheelie bins

Suited for outdoor environments, the Wheelie Bin Covers are ideal for exhibitions, festivals and school fêtes.

A clear pocket allows for customised signage inserts. Available in 4 colours for sorting waste from recycled material. Custom colours are available for special orders.

- Suitable for 240 Litre Bins
- Red, Yellow, White & Black

LINER BAGS bin liners

Use the right accessories for your bin will ensure you get the right fit every time without excess bags being exposed.

Bags are available from all Container Connection outlets.

- Suitable for Littersmart Liners
- Strong and durable

SECURITY cables

Security wire is an optional extra, which can be fitted to prevent misuse of bin lids and smoking attachments.

- Made from stainless steel
- Custom made to fit
- Prevent theft or loss

Product Name: BIN COVERS	Dimensions (cm)	Capacity (Litres)
Wheelie Bin Cover	73L x 59W x 106H	240L Bins

Product Name: LINER BAGS	
Bin Liners	Multiple Sizes Available

Product Name: CABLES	
Security Cables	Options Available



DESIGN SOLUTIONS

Collaborate + Design

Sometimes you need a product which is job specific. We are recognised as a leader in innovation and can manage the most difficult concepts. We add intellect, we collaborate to produce superior Australian designed and manufactured products for domestic and international markets. Our team of outstanding designers, manufacturers and distributors are ready to collaborate on your next project.

QANTAS STORY

Graeme Smith from The Container Connection NSW and Norman Johnson from Palamont, collaborated with the QANTAS Design team on a concept for recycling newspapers and magazines from other recycling material.

The brief included:

- Style – the unit had to look good in the departure lounges of the domestic terminals.
- Size – to be compact, yet provide two useful receptacles for newspapers/magazines and other recycling waste.
- Removable Liner Bins – keeps plastic liner bags out of sight.
- Hinged Lid – staff do not have to remove the lid and put aside while emptying the bins.
- Lockable Lid – improves security and safety.
- OH & S – the unit had to pass a workplace safety risk assessment.
- Green Credentials – materials had to have a high recycled content.
- Country of Origin – Australian design and manufacture was preferred.
- Signage – Specific QANTAS signage was supplied. Mould in Graphics was the selected form of signage.

Attention to detail included hole shapes and sizes, as well as the shape of the base at the rear to provide maximum stability when the lid is hinged back, with a lock specific to the needs of QANTAS. Once the prototype was approved, a mould was made to produce this modern, functional recycling centre in high quality recycled polyethylene, which is a Green Star rated material.

Finished Product



Raw Concept

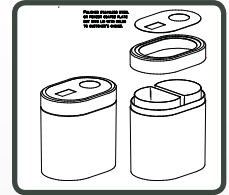

Initial Render



Initial Details



Line Drawing

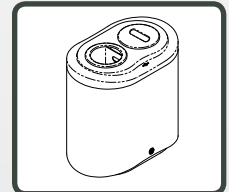

Final Design Concept



Prototype



Mould to Manufacture



PRODUCT MATRIX

Product	Name	Page	Size (cm)	Includes	Capacity
TOT	TOT Bin Senior	2	60 \varnothing x 90 ^H	Co-polymer liner	86
	TOT Bin Junior	2	46 \varnothing x 70 ^H	Co-polymer liner	40
Coral Series	Coral Bin	4	60 \varnothing x 96 ^H	Co-polymer liner	79 litres
	Coral Bench Planter	3	69 ^L x 49 ^W x 118 ^H	(takes grow pot 13" / 330 mm)	n/a
	Coral Bench Mid Seat Bend	3	148 ^L x 83 ^W x 44 ^H		n/a
	Coral Bench End Piece	3	44.5 ^L x 46 ^W x 44 ^H		n/a
	Coral Planter 900	3	51 \varnothing x 102 ^H	(takes grow pot 13" / 330 mm)	n/a
Transit Bin	Transit Bin	6	75 ^L x 50 ^W x 75 ^H	Co-polymer liner	2 x 60 litres
	Transit Bin Inclusions	Key Locking Lid			
		Lid Brace Cable			
		2 x Bin Liners with inbuilt handles			
	Additional Options	Stainless Steel Spinning			
		Custom Decals			
		Custom Powder Coated Spinning			
Olympian Series	Olympian Shopper - Recycle	8	54 \varnothing x 80 ^H	Co-polymer liner	79 litres
	Olympian Shopper - Wide Top	8	54 \varnothing x 80 ^H	Co-polymer liner	79 litres
	Olympian Shopper Deluxe - Wide Top	8	54 \varnothing x 80 ^H	Co-polymer liner	79 litres
	Olympian Shopper Deluxe - Recycle	8	54 \varnothing x 80 ^H	Co-polymer liner	79 litres
	Olympian Recycle Shopper Duo	8	115 ^L x 54 ^W x 80 ^H	Co-polymer liner	2 x 79 litres



TOT



CORAL



TRANSIT



OLYMPIAN



CHATSWOOD



ATTACHE



DIPLOMAT



BUY LOCAL, Reduce your Carbon Miles

Carbon Miles is now firmly part of the new carbon lingo. This is a way of expressing how far an item has travelled before it reaches you, and therefore how much CO₂ has been emitted during freighting. A better concept is probably 'embodied energy', which takes account of all the carbon, water and energy that goes into producing any manufactured item. Either way, a good rule of thumb is that if you buy something that has been produced locally, it will usually have a lower CO₂ tag attached to it. Buying Australian-made manufactured products is a carbon-friendly option and will make a difference to your climate change impact, and help the local economy.

Product	Name	Page	Size (cm)	Includes	Capacity
Chatswood Series	Chatswood Open Top	10	50 ^L x 50 ^W x 79 ^H	Co-polymer liner	79 litres
	Chatswood Hooded Top - 2 Sided Entry	10	50 ^L x 50 ^W x 96 ^H	Co-polymer liner	79 litres
	Chatswood Hooded Top - 4 Sided Entry	10	50 ^L x 50 ^W x 96 ^H	Co-polymer liner	79 litres
	Chatswood Hooded Top - Bottle Opening	10	50 ^L x 50 ^W x 96 ^H	Co-polymer liner	79 litres
	Chatswood Tray Return - 1 Side Swing Flap	10	50 ^L x 50 ^W x 96 ^H	Co-polymer liner	79 litres
	Chatswood Swing Top - 2 Sided Entry	10	50 ^L x 50 ^W x 96 ^H	Co-polymer liner	79 litres
	Chatswood Swing Top - 1 Sided Entry	10	50 ^L x 50 ^W x 96 ^H	Co-polymer liner	79 litres
Attache Series	Attache Slimline Open Top Senior	12	26 ^Ø x 60 ^H	Co-polymer liner	25 litres
	Attache Slimline Litter / Ash Senior	12	26 ^Ø x 60 ^H	Co-polymer liner	18 litres
	Attache Slimline Open Top Junior	12	26 ^Ø x 40 ^H	Co-polymer liner	16.5 litres
	Attache Classic Open Top Senior	12	37 ^Ø x 77 ^H	Co-polymer liner	40 litres
	Attache Classic Open Top Junior	12	37 ^Ø x 62 ^H	Co-polymer liner	20 litres
	Attache Slimline Recycle Duo Senior	12	55 ^L x 26 ^W x 60 ^H	Co-polymer liner	2 x 25 litres
	Attache Slimline Recycle Duo Junior	12	55 ^L x 26 ^W x 40 ^H	Co-polymer liner	2 x 16.5 litres
	Attache Classic Recycle Duo Senior	12	77 ^L x 37 ^W x 77 ^H	Co-polymer liner	2 x 40 litres
Attache Classic Recycle Duo Junior	12	77 ^L x 37 ^W x 60 ^H	Co-polymer liner	2 x 30 litres	
Diplomat Series	Diplomat Open Top Senior	14	37 ^Ø x 79 ^H	Co-polymer liner	40 litres
	Diplomat Litter / Ash Senior 1 Sided Entry	14	37 ^Ø x 79 ^H	Co-polymer liner	30 litres
	Diplomat Litter / Ash Senior 2 Sided Entry	14	37 ^Ø x 79 ^H	Co-polymer liner	30 litres
	Diplomat Open Top Junior	14	37 ^Ø x 62 ^H	Co-polymer liner	30 litres
	Diplomat Litter / Ash Junior 1 Sided Entry	14	37 ^Ø x 62 ^H	Co-polymer liner	20 litres
	Diplomat Senior Recycle Open Top	14	37 ^Ø x 79 ^H	Co-polymer liner	40 litres
	Diplomat Junior Recycle Open Top	14	37 ^Ø x 62 ^H	Co-polymer liner	30 litres
	Diplomat Recycle Duo Senior	14	79 ^L x 37 ^W x 79 ^H	Co-polymer liner	2 x 40 litres
Diplomat Recycle Duo Junior	14	79 ^L x 37 ^W x 62 ^H	Co-polymer liner	2 x 30 litres	



ecospecifier assesses and presents information on sustainable and healthy materials, products, technologies, training and published materials relevant to city design, infrastructure and landscaping, building, construction and interior fit out, and some operational and maintenance functions.



Think Green
Think LitterSmart

Littersmart is manufactured in a recyclable material. Bins can be made in 100% recycled polyethylene on request.

LITTERSMART



BRISBANE

SYDNEY

MELBOURNE

ADELAIDE

PERTH

NZ

P : 07 3712 0466
F : 07 3712 0488

P : 02 9624 4114
F : 02 9624 4039

P : 03 9764 1080
F : 03 9764 1995

P : 08 8336 3066
F : 08 8365 8977

P : 08 9309 2442
F : 08 9309 2787

P : 04 939 6666
F : 04 939 6696